

□ AISI 316L DP TYPE - EN 14420-7:2004 CAM & GROOVE DIFLON F17

The fast fitting is used in chemical, pharmaceutical and food industries.

The CELERITY in connecting hoses, to equipments and plants is what distinguishes this type of fitting from the other ones.

The standard construction material is AISI 316L.

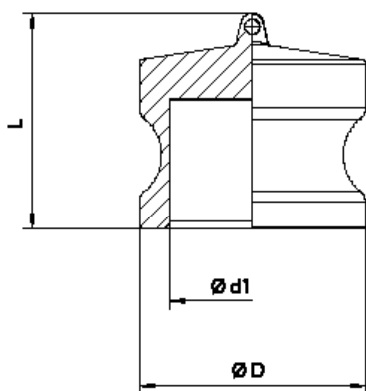

RECOMMENDED GASKET

DIFLEX CAM & GROOVE gasket, resistant to all acids and chemicals, pharmaceuticals and food products with temperatures from -170 °C to +270 °C and pressures up to 50 bar.

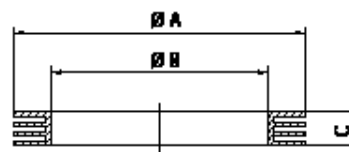

GASKET CAM & GROOVE

DN	L	Ø D	Ø d1
15 - 1/2"	38	24,5	13
20 - 3/4"	38	29	20
25 - 1"	44	36,5	25
32 - 1 1/4"	51	44,5	30
40 - 1 1/2"	51	53	38
50 - 2"	60	63	48
65 - 2 1/2"	63	75,5	59
80 - 3"	68	91	74
100 - 4"	71	120	103

DN	Ø A	Ø B	C
15 - 1/2"	26	17	3,96
20 - 3/4"	35	22	5,53
25 - 1"	40	27	6,35
32 - 1 1/4"	49	34	6,35
40 - 1 1/2"	55	41	6,35
50 - 2"	66	51	6,35
65 - 2 1/2"	79	60	6,35
80 - 3"	94	76	6,35
100 - 4"	123	102	6,35